

General Description

The SY8021L/8021 are high-efficiency 1.5MHz synchronous step-down DC-DC regulator ICs capable of delivering up to 1A and 1.5A output currents, respectively. The SY8021 operates over a wide input voltage range from 3V to 5.5V and integrate main switch and synchronous switch with very low RDS(ON) to minimize the conduction loss.

Low output voltage ripple and small external inductor and capacitor sizes are achieved with 1.5MHz switching frequency.

Applications

- LCD TV
- WiFi Card
- GPS
- Access Point Router
- Set Top Box

Features

- low Rds(on) for internal switches (top/bottom):
 - SY8021L: 250/200mohm, 1A
 - SY8021: 200/150mohm, 1.5A
- 3-5.5V input voltage range
- 1.5MHz switching frequency minimizes the external components
- Internal softstart limits the inrush current
- 100% dropout operation
- Compact and thermally enhanced package: SO8E

Ordering Information

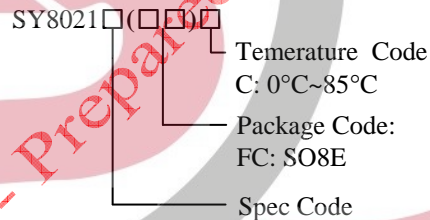

Typical Applications

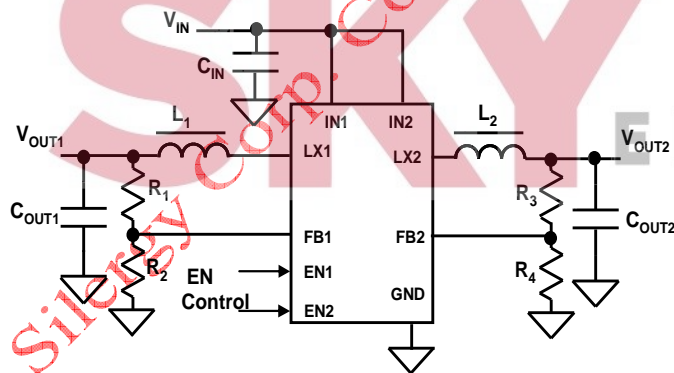

Figure 1

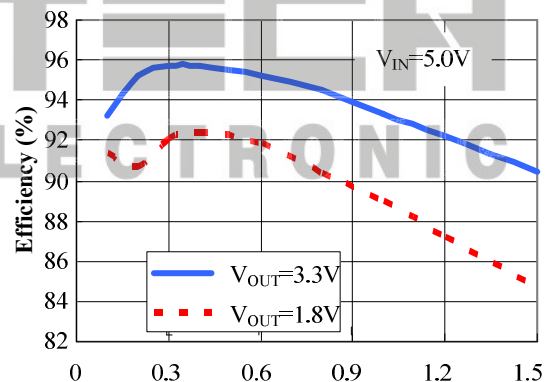
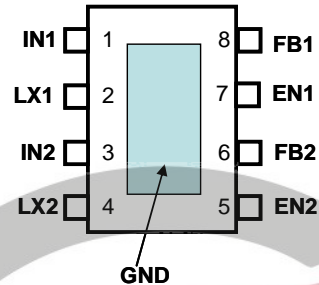

Figure2 Efficiencyvs Load Current

Pinout (top view)



Pin Name	Pin Number	Pin Description
EN1,2	7,5	Enable control. Pull high to turn on. Do not float.
GND	9 (exposed paddle)	Ground pin. The paddle must be soldered to the ground plane on the PCB.
LX1,2	2,4	Inductor pin. Connect this pin to the switching node of inductor
IN1,2	1,3	Input pin. Decouple this pin to GND paddle with at least 10uF ceramic cap
FB1,2	8,6	Output Feedback Pin. Connect this pin to the center point of the output resistor divider (as shown in Figure 1) to program the output voltage: $V_{out}=0.6*(1+R1/R2)$

Absolute Maximum Ratings (Note 1)

Supply Input Voltage	6V
Enable, FB Voltage	$V_{IN} + 0.6V$
Power Dissipation, P_D @ $T_A = 25^\circ C$ SO8E	1W
Package Thermal Resistance (Note 2)	
SO8E, θ_{JA}	50°C/W
SO8E, θ_{JC}	10°C/W
Junction Temperature Range	-150°C
Lead Temperature (Soldering, 10 sec.)	260°C
Storage Temperature Range	-65°C to 150°C
ESD Susceptibility (Note 2)	
HBM (Human Body Mode)	2kV
MM (Machine Mode)	200V

Recommended Operating Conditions (Note 3)

Supply Input Voltage	3V to 5.5V
Junction Temperature Range	-40°C to 125°C
Ambient Temperature Range	-40°C to 85°C

Electrical Characteristics

($V_{IN} = 5V$, $V_{OUT} = 2.5V$, $L = 2.2\mu H$, $C_{OUT} = 10\mu F$, $T_A = 25^\circ C$, $I_{MAX} = 1A$ unless otherwise specified)

Parameter	Symbol	Test Conditions	Min	Typ	Max	Unit
Input Voltage Range	VIN		3		5.5	V
Shutdown Current	ISHDN	EN=0			10	μA
Feedback Reference Voltage	VREF		0.588	0.6	0.612	V
FB Input Current	IFB	VFB=VIN	-50		50	nA
PFET RON	RDS(ON),P	SY8021L		0.25		Ω
		SY8021		0.2		Ω
NFET RON	RDS(ON),N	SY8021L		0.20		Ω
		SY8021		0.15		Ω
PFET Current Limit	I _{LIM}	SY8021L	1.2			A
		SY8021	1.8			A
EN rising threshold	VENH		1.5			V
EN falling threshold	VENL				0.4	V
Input UVLO threshold	VUVLO				2.4	V
UVLO hysteresis	VHYS			0.1		V
Oscillator Frequency	FOSC	IOUT=100mA		1.5		MHz
Min ON Time				50		ns
Max Duty Cycle			100			%
Thermal Shutdown Temperature	TSD			160		C

Note 1: Stresses listed as the above “Absolute Maximum Ratings” may cause permanent damage to the device. These are for stress ratings. Functional operation of the device at these or any other conditions beyond those indicated in the operational sections of the specifications is not implied. Exposure to absolute maximum rating conditions for extended periods may remain possibility to affect device reliability.

Note2: θ_{JA} is measured in the natural convection at $T_A = 25^\circ C$ on a low effective single layer thermal conductivity test board of JEDEC 51-3 thermal measurement standard.

Note3. The device is not guaranteed to function outside its operating conditions

SO8E Package outline & PCB layout design

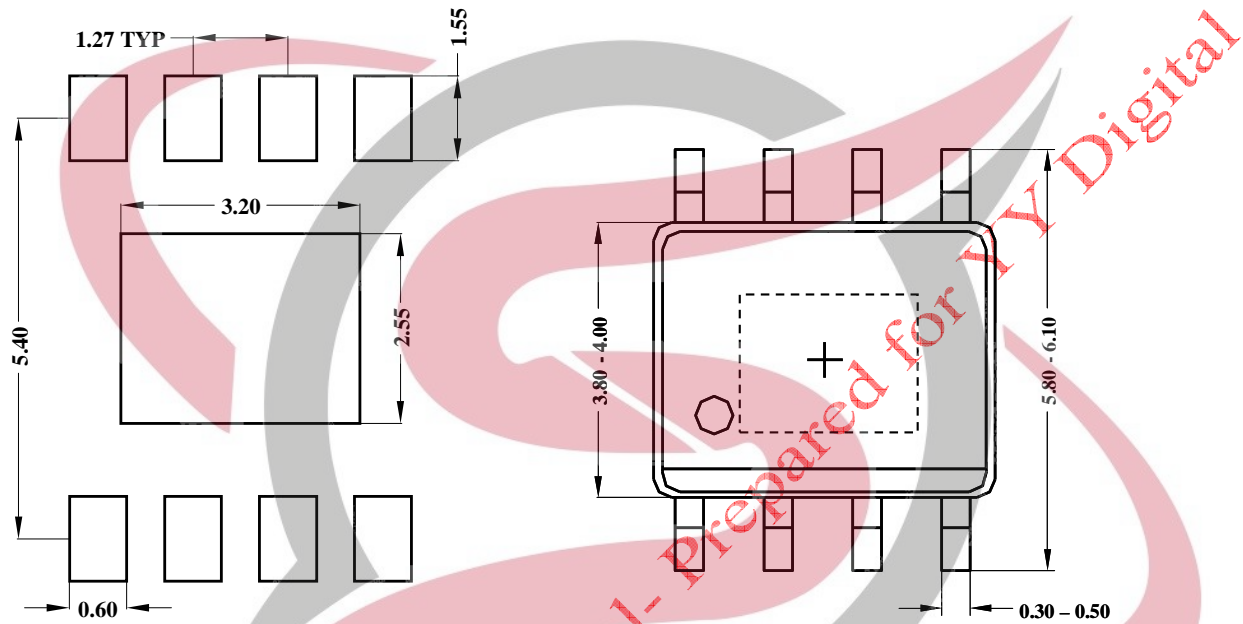

Recommended Pad Layout

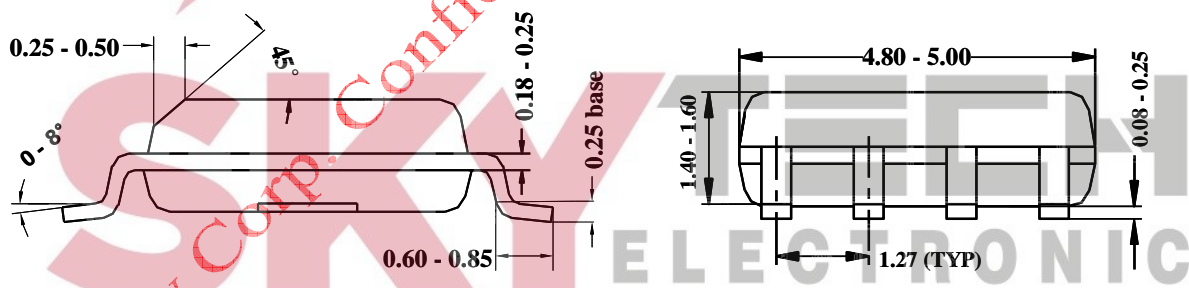

Notes: All dimension in MM
 All dimension don't not include mold flash & metal burr